

PROPER FITTING MAKE UP INSTRUCTIONS

- Select & Inspect Appropriate Tubing
- Fully Insert Tubing
- Mark Reference Point on Tube Nut
- Securely Hold Body & Rotate Nut Clockwise (1-1/4 turns)

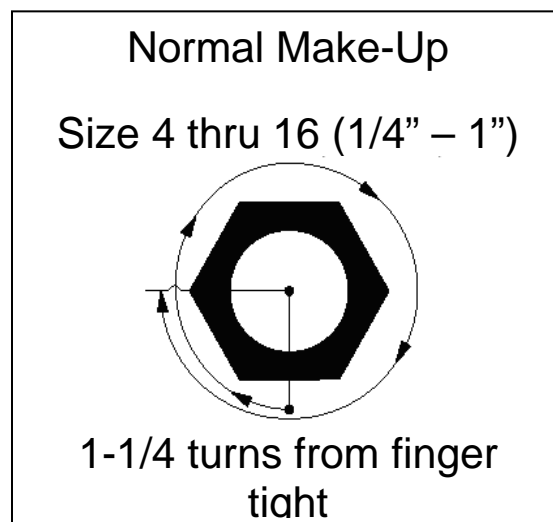

PORT CONNECTORS & PLUGS

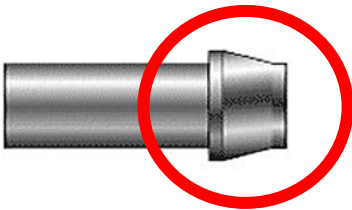

Port Connector

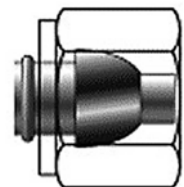

Plug

Installation Steps

- Insert Port Connector or Plug onto Fitting Body
- Tighten Nut Finger Tight
- Rotate Nut 1/4 Turn

FITTING REMAKE

To get the maximum number of remakes:

1. Mark the fitting body and nut (A-A) before disassembly
2. Before retightening, make sure the assembly has been inserted into the fittings until the ferrules seat in the body
3. Retighten the nut by hand or with a wrench to the original position as indicated by lining up the previous marks
 - A noticeable increase in the mechanical resistance will be felt indicating the ferrules are being re-sprung in the sealing position
4. Snug the nut $1/12$ turn ($1/2$ hex flat), as shown from A to B, past the original position

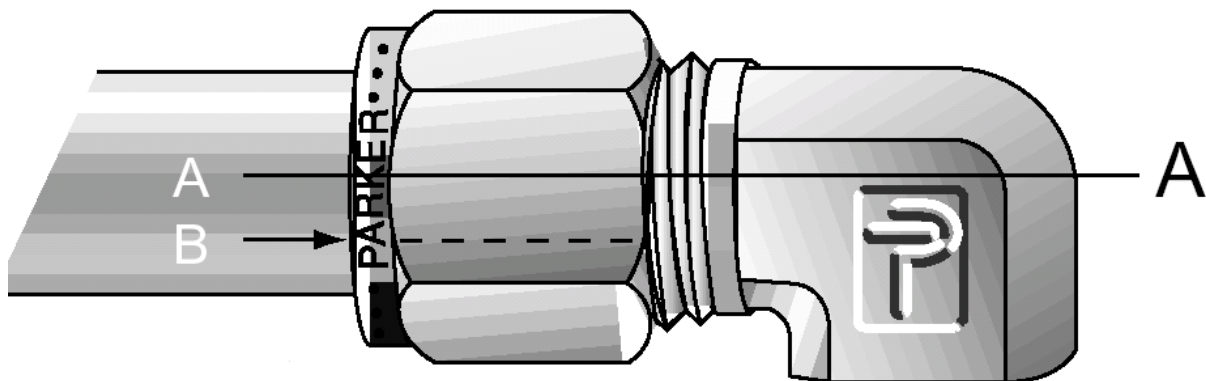

ENGINEERING **YOUR** SUCCESS.