

## VACUUM TANK PACKAGE

### For Poultry Processing Tumblers

The Vacuum Tank Package (VTP) is a proven design that effectively replaces rotary vane pumps with liquid ring vacuum pumps. All of the water used for the liquid ring seal is carried around the piping to the tank. This washes any accumulated carryover solids through the pump, helps keep the pump cool to the touch, and nearly eliminates water consumption.

Fluid Flow's Vacuum Tank Packages vary in size from 10HP to 20HP to fit a variety of applications.



### WHY USE THE VTP?

- Longer pump life vs. rotary vane pumps
- Handles liquid and food carryover
- Fewer moving parts

### WHO USES THE VTP?

- Meat and poultry plants
- Food processing plants
- Plants that mix and marinate products

### VTP SERIES BENEFITS

- Different sizes to fit your application
- Less downtime than rotary vane pumps
- Handles liquid and food carryover
- Huge water savings = huge savings on expenses
- Fewer moving parts = less pump failure

### HOW THE VTP WORKS

- Air at pump inlet is mixed with sealing water to achieve isothermal vacuum and compression
- The air/water mixture is separated at the outlet
- The water is reintroduced at pump suction
- Only an occasional amount of make-up water is required and differs by temperature of water and environment

## LIQUID RING VACUUM PUMPS

HIGHEST REMOVAL EFFICEINCY

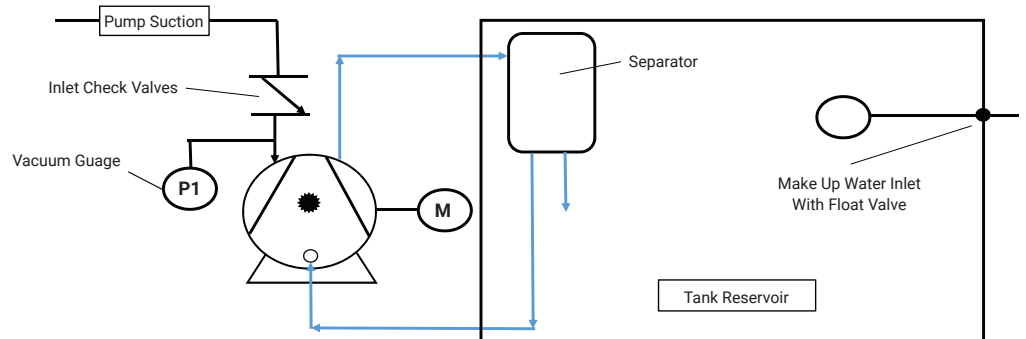
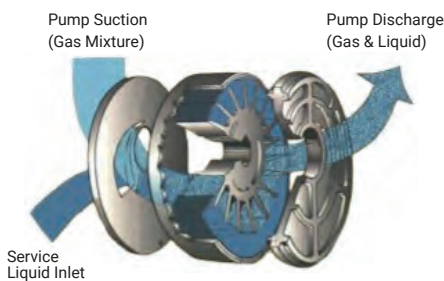

## TECHNICAL SPECIFICATIONS

MODEL	SPEED (RPM)	MOTOR (HP)	Capacity at 20" (ACFM) <sup>1</sup>	Capacity at 25" (ACFM) <sup>1</sup>	Capacity at 28" (ACFM) <sup>1</sup>	Capacity at 28.9" (ACFM) <sup>1</sup>	WATER FLOW CIRCULATED (GPM)	SUCTION DISCHARGE SIZE (INCHES)	DIMENSIONS (L" x W" x H") <sup>2</sup>	WEIGHT (LBS)
LEMR250-TNK	1750	10	154	145	110	80	5	2	50 x 40 x 38	1200
LEHR360-TNK	1750	15	218	200	158	75.5	10	3	60 x 42 x 50	1900
LEHR460-TNK	1750	20	301	272	219	135	10	3	60 x 42 x 50	1900

<sup>1</sup> Capacity in ACFM at inlet pressure at sea level for air at 20°C (68°F) using 15°C (59°F) water as service liquid, with atmospheric discharge pressure.

<sup>2</sup> All dimensions and weights are approximate. Data is subject to change without notice.

## VTP APPLICATION SOLUTION

### Problem:

Meat and poultry plants use vacuum to improve marinating chicken, bacon, pork and other pre-marinated meats. Central vacuum systems and rotary vane vacuum pumps have been widely used to supply vacuum to tumblers. Marinade carryover and other debris shorten the life of rotary vane pumps. The most common issues when dealing with other liquid ring vacuum pumps are high water usage and disposal costs. Service life for oil-sealed rotary vane vacuum pumps can be as little as two months. With regular maintenance, a rotary vane pump may last two years supplying vacuum to a tumbler.

Regular maintenance includes cleaning the inlet separator, frequent oil changes, and lube filter change-outs. Because the pump is in a cold room and installed with the tumbler, maintenance is difficult.

### Solution:

Since 1999, Fluid Flow Products has been offering a Vacuum Tank Package system that replaces rotary vane pumps. In some poultry plants, Fluid Flow's Tumbler Vacuum Systems have been in service with minimal maintenance for more than seven years. Most OEMs today use a solution similar to Fluid Flow's Vacuum Tank Package instead of rotary vane pumps.

Fluid Flow's Vacuum Tank Systems also feature liquid ring vacuum pumps, which have one moving part—an impeller keyed to a shaft. These pumps create vacuum by sealing with a ring of water. The water used is carried through heat-dissipating piping to the integrated tank, reducing water consumption to near zero. The system is typically cleaned and drained daily to avoid pump damage caused by product and marinade carryover. The unit is installed adjacent to the tumbler in the cold room (or sometimes in a close equipment room) and is furnished with casters.

